

Installation Instructions

Highway Mounts For 1" Engine Guards

#GL18004

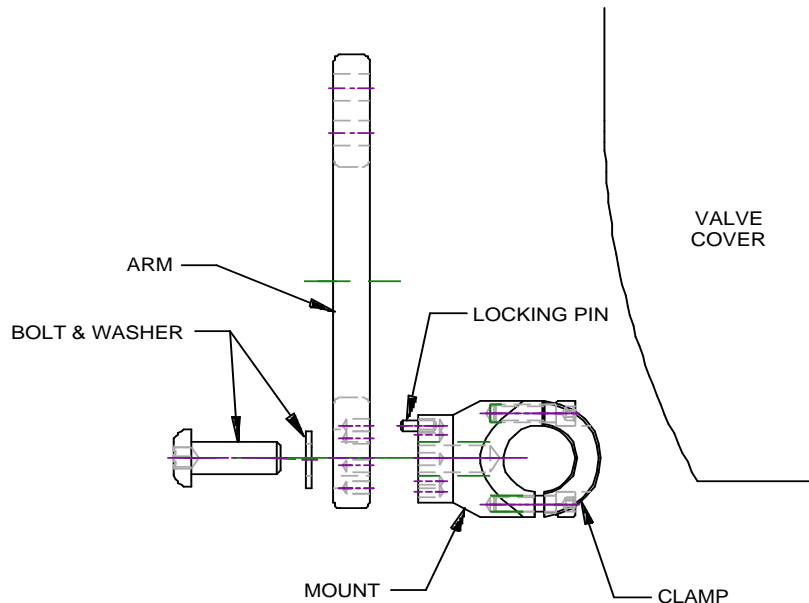

Notice that if you hold the mount and clamp together there is a gap only on one side. This gap should be at the bottom of the engine guards.

Loosely assemble the mount and clamp onto the engine guard tube. Next rotate the assembly upward as far as possible to gain better access to the upper screws, tighten the upper screws securely. Next loosely install the large bolt, washer, locking pin and arm with the arm pointing downward. Rotate the assembly back down so that the arms will be upright or vertical when viewed from the front or rear. *Note: You may want the arms to lean outward slightly to give more room for your legs around the fairing lowers.* Now tighten the lower screws securely.

Adjusting the arm angle. Move the arms to the desired position as follows Notice that there are 8 holes in the mount and 7 in the arm. By leaving the pin in the mount and rotating the arm to its next hole will move the arm 50 deg. When you get close to the desired angle you may make adjustments in 5 deg. increments by moving the pin to the next hole in both the mount and the arm. Moving to the next set of holes clockwise will move the arm counter clockwise 5 deg. Moving the pin to the next set of holes counter clockwise will move the arm clockwise 5 deg. This will provide 72 different mounting angles total. Install the large bolt and washer, tighten securely and install your pegs or hi-way boards. *Note: When installing boards put the lock or star washer between the board and the arm to prevent them from rotating under heavy pressure.*

RIVCO Products, Inc
440 S. Pine St.
Burlington, WI 53105
(262) 763-8222
www.rivcoproducts.com